

FARAD[®] BARS

made in italy

Evolution Srl unipersonale, Via A. De Gasperi 26/A, 12040 Sanfrè (CN) Italy

info@faradworld.com



+39 0172 58575



BS 077

SEAT ALTEA 2004-2015
SEAT TOLEDO 2005-2013

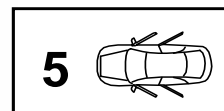

I Istruzioni di montaggio

F Instructions de montage

PL Instrukcja montażu

D Einbauanleitung

GB Fitting instructions

E Instrucciones de montaje

NL Inbouwhandleiding

SWE Montageanvisnin

KIT BS

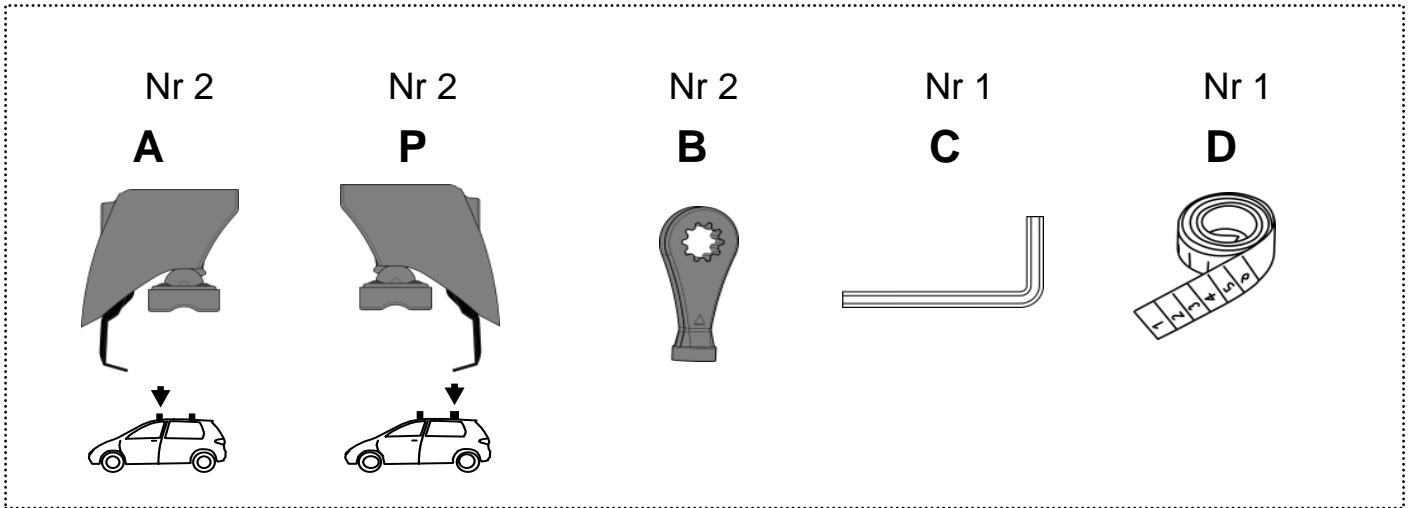

+

KIT ALU

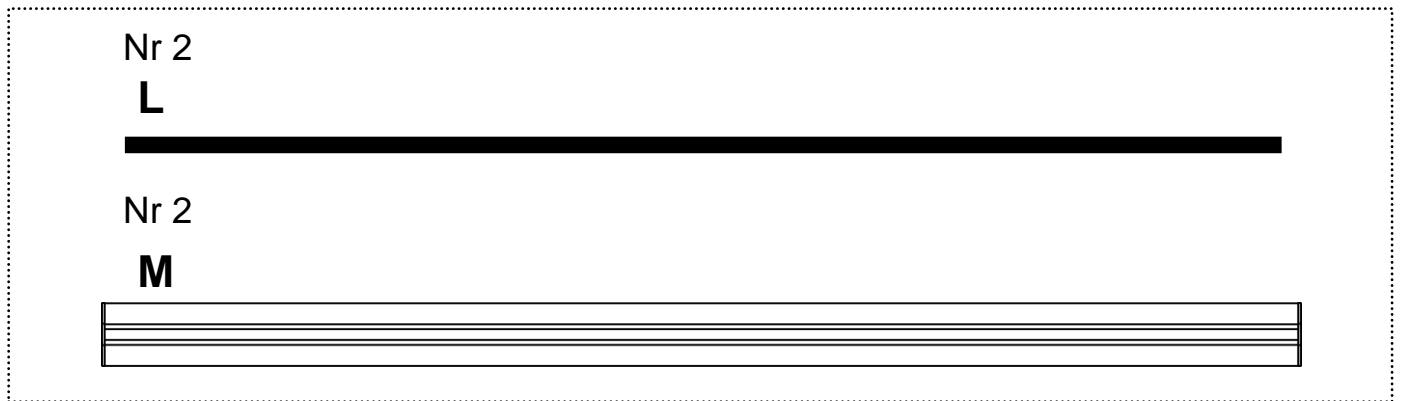

=

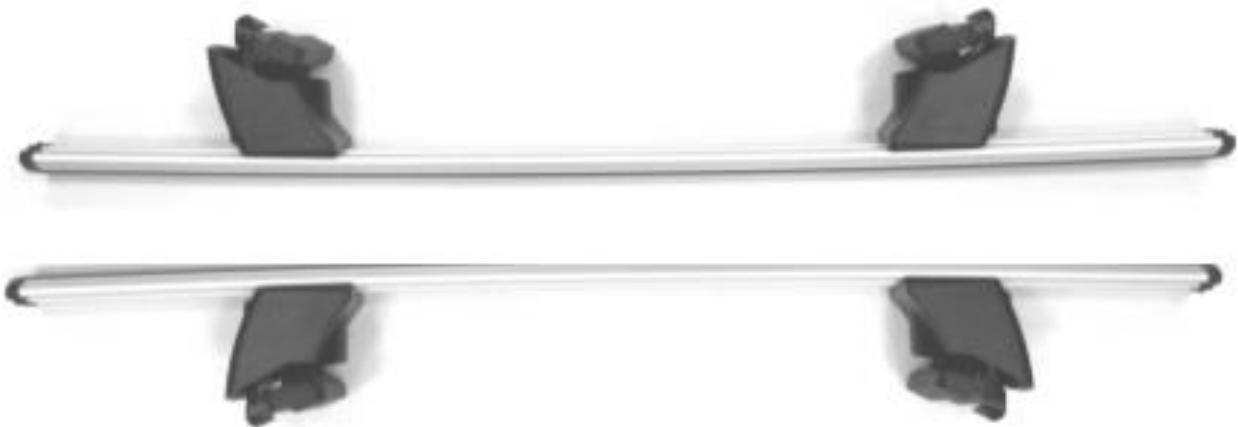

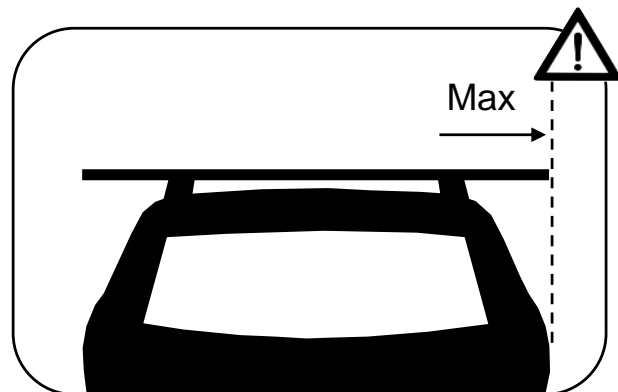
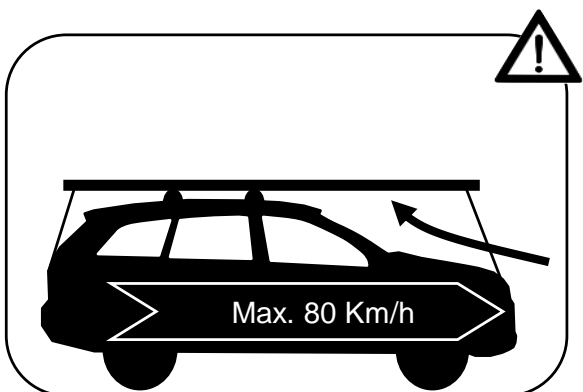
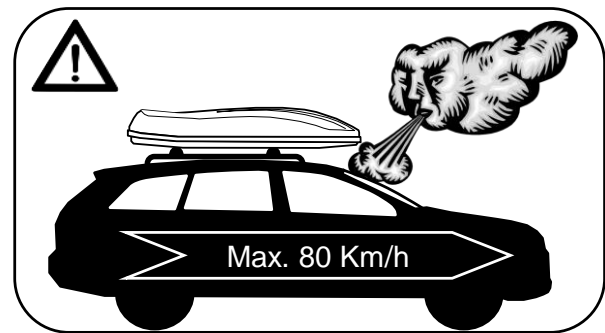
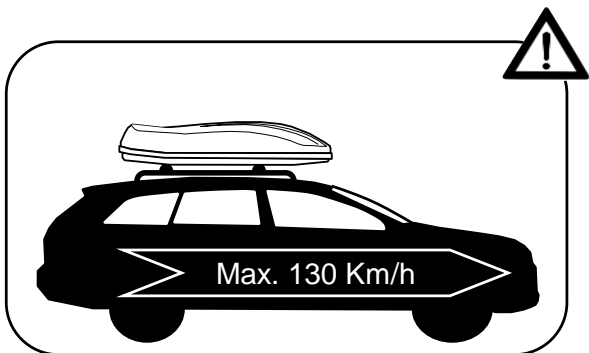
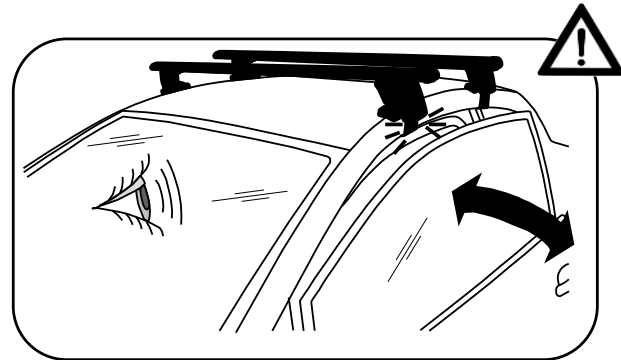
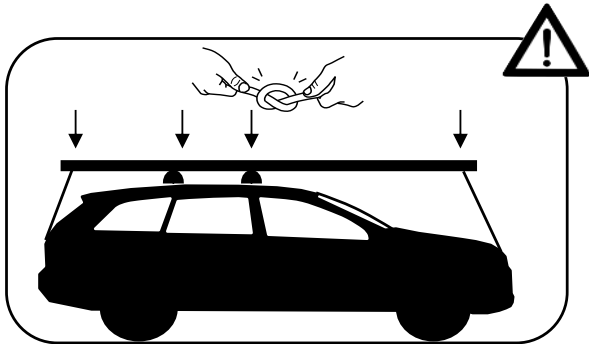
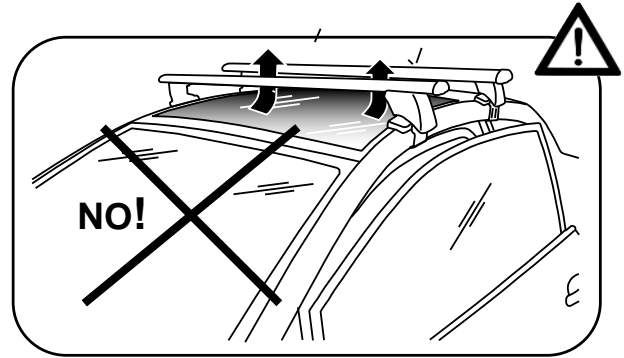
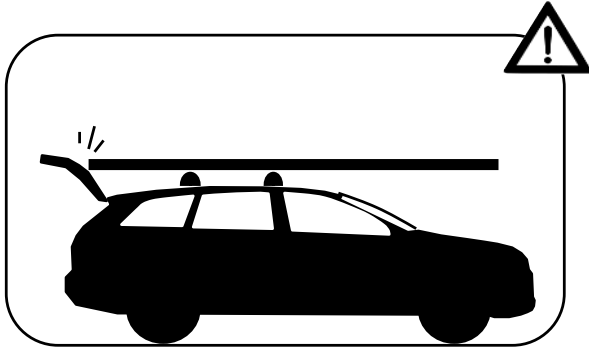
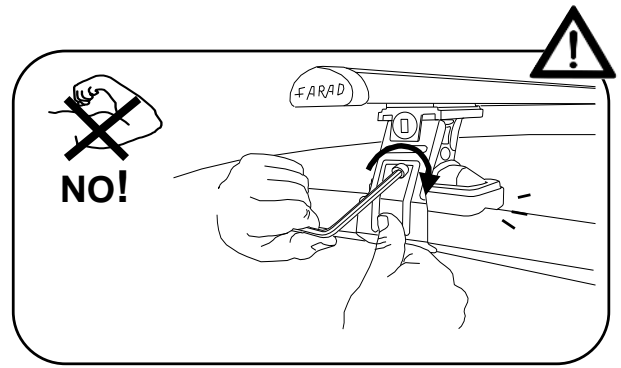
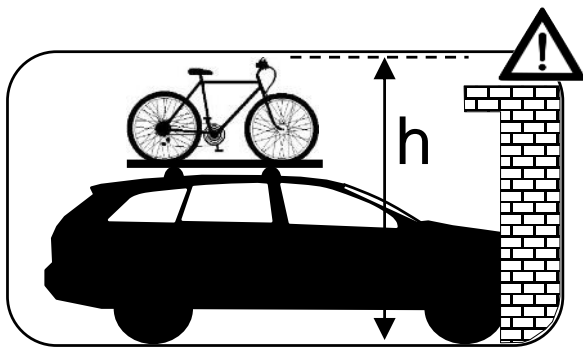

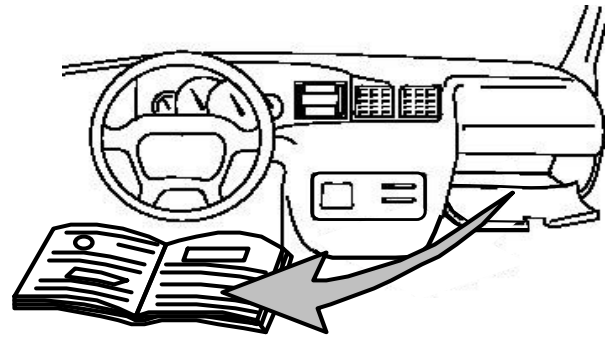
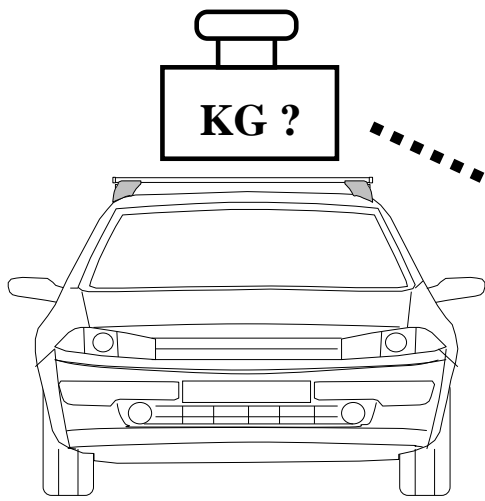

- I Controllare carico del tetto sul manuale dell'auto
- PL Sprawdz ładowność dachu w instrukcji
- GB Check roof load capacity in car instruction
- NL check de handleiding belasting van het dak van de auto
- F vérifier le chargement manuel du toit de la voiture
- D überprüfen Sie die manuelle Beladung der Autodach
- E comprobar la carga manual del techo del coche
- SWE kontrollera manuell inläggning på taket av bilen

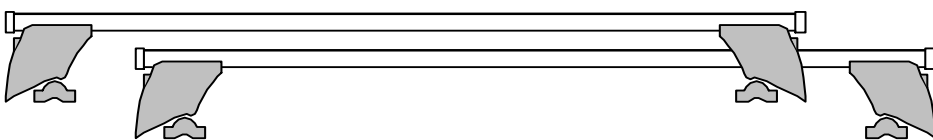
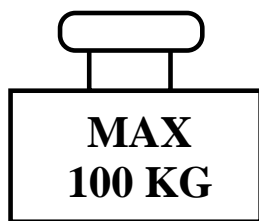
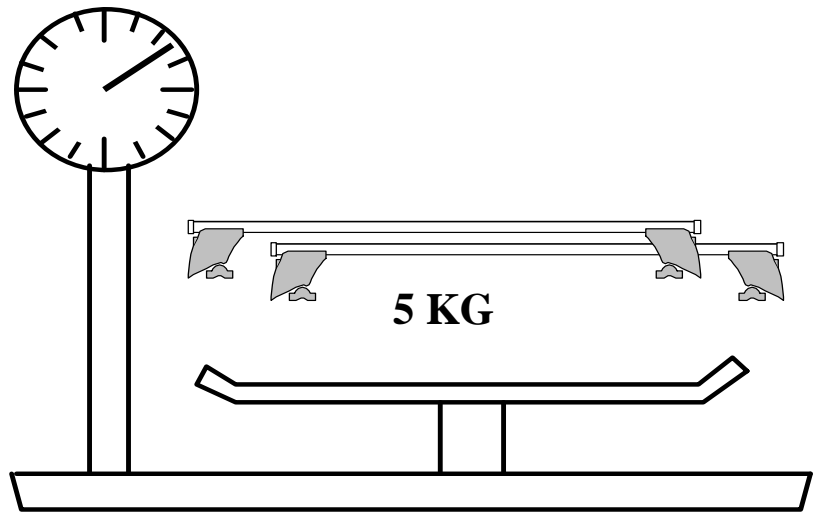

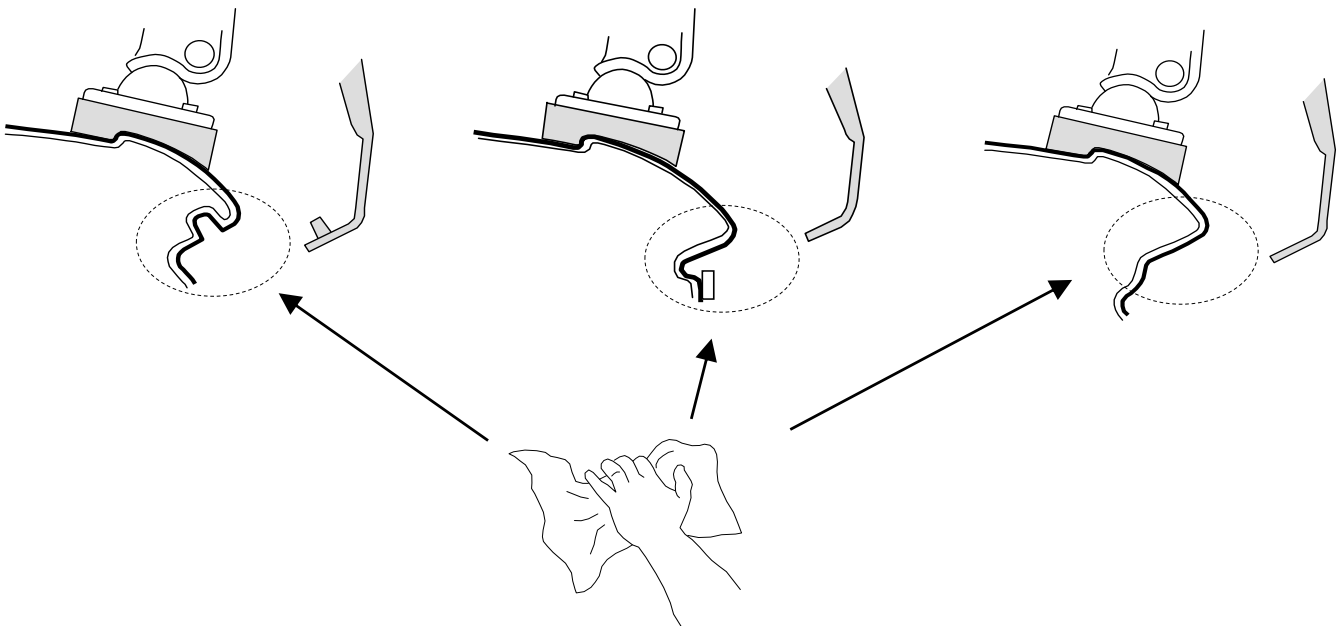
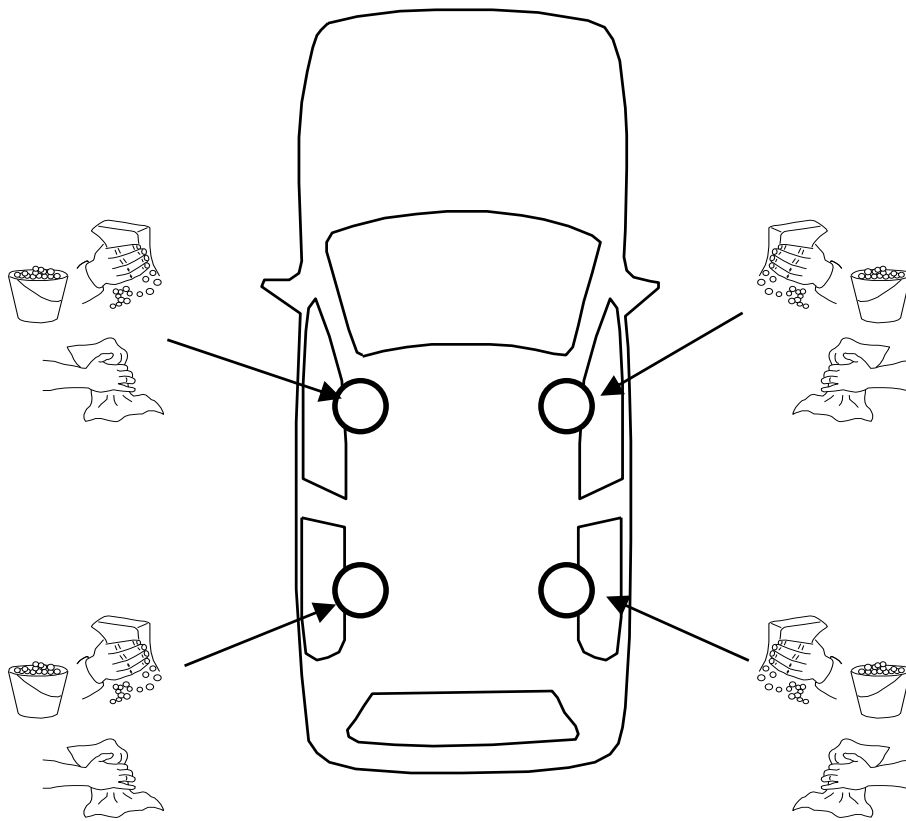

I **Montaggio Barra Anteriore**

F **Fixation Barre Avant**

PL **Montaż Bagażnika Bazowego Tylnego**

GB **Fitting Front Roof Bar**

D **Montage Vorderes Dachträgers**

NL **Montage Voorste Dakdrager**

SWE **Montering Av Främre Lasthållaren**

E **Fijación Barra Frontal**

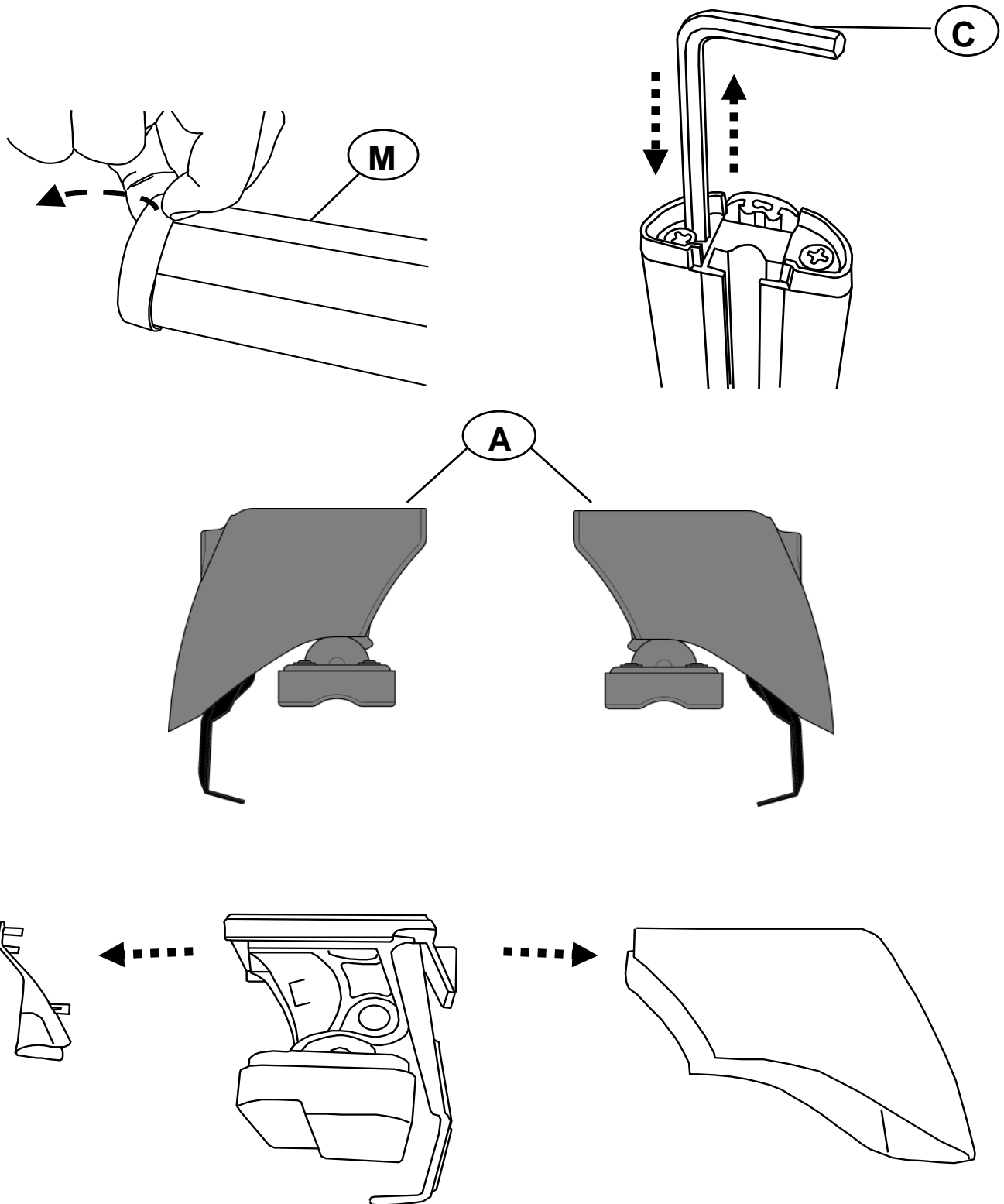



M

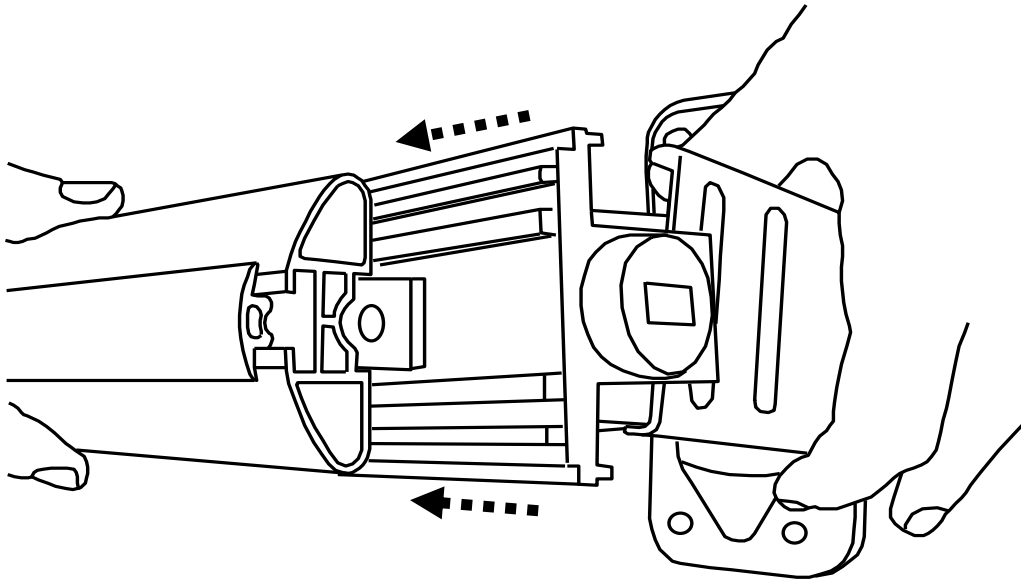
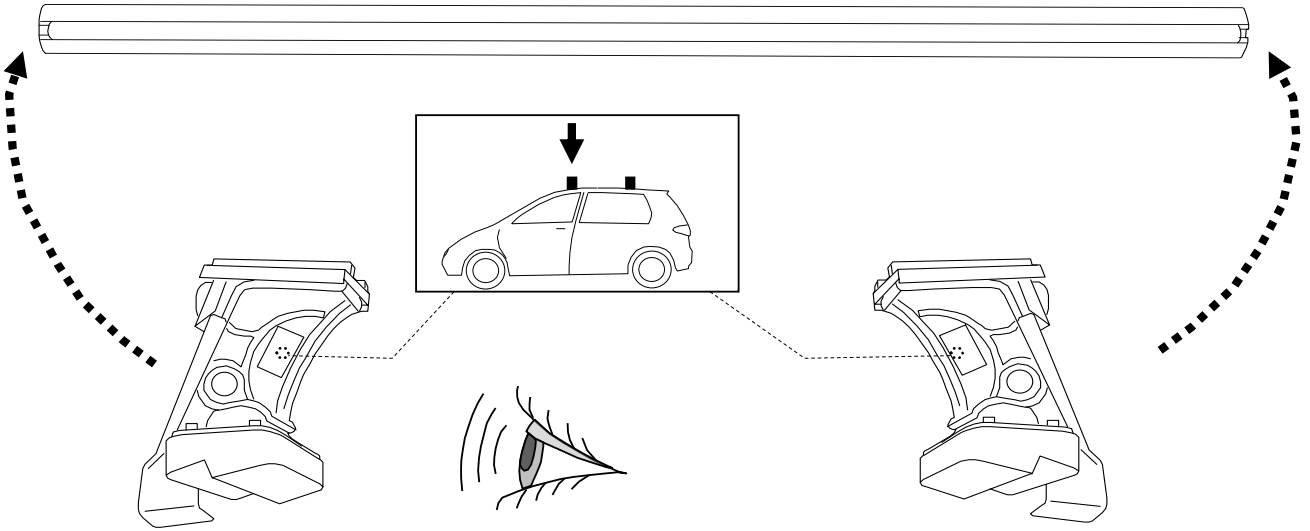

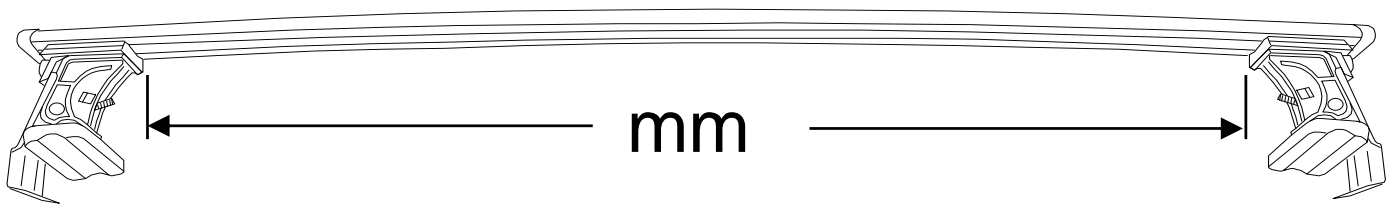

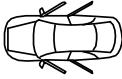
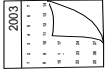

			R	mm
SEAT	ALTEA	5	R= 31	1020
SEAT	TOLEDO	5	R= 30	1015

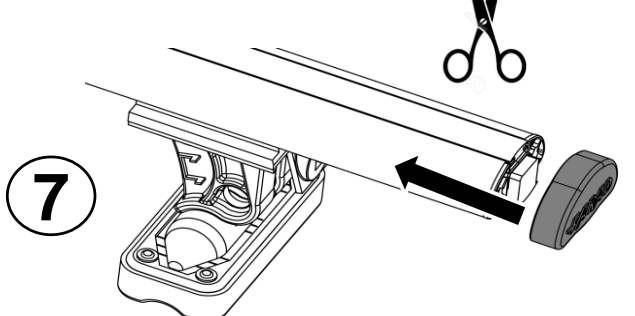
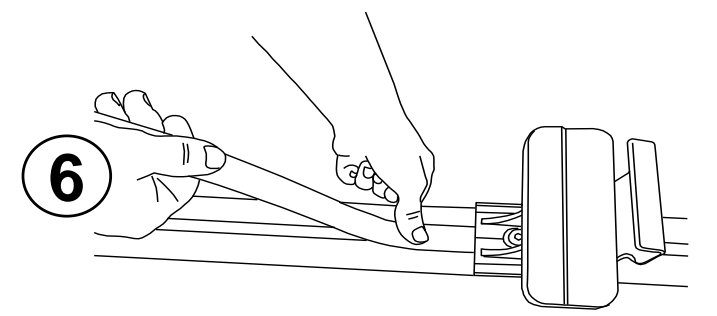
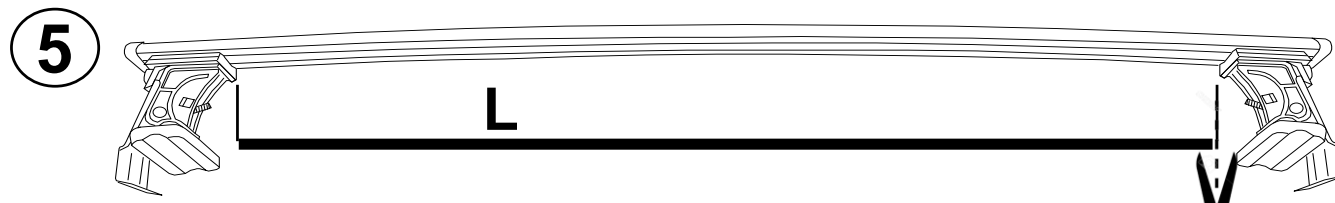
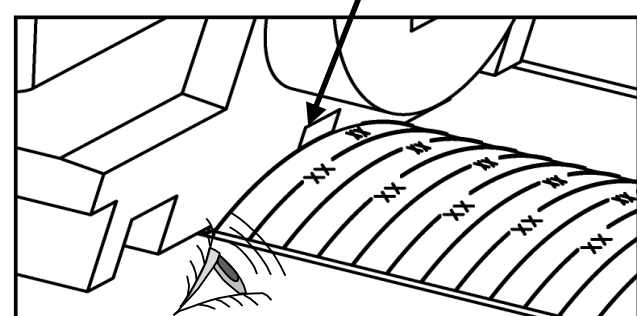
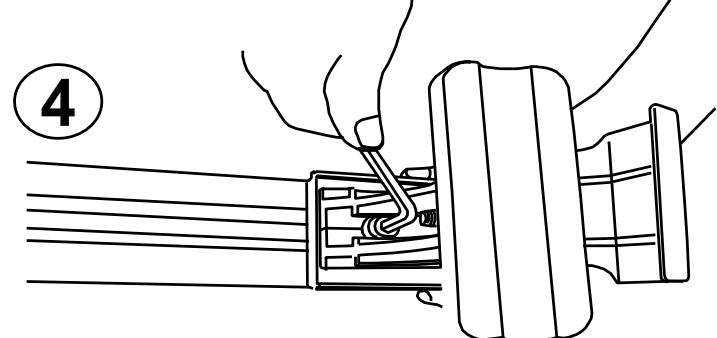
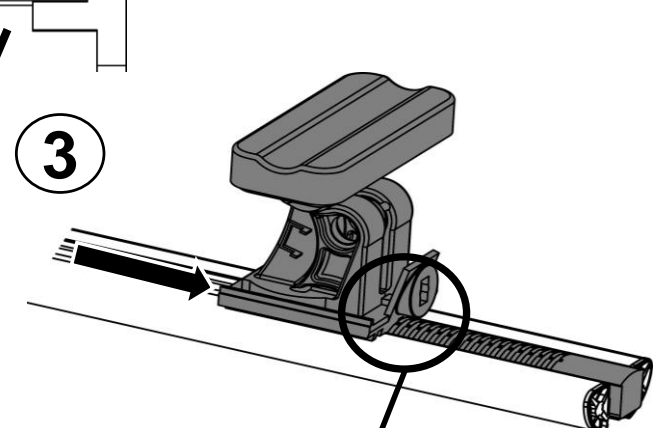
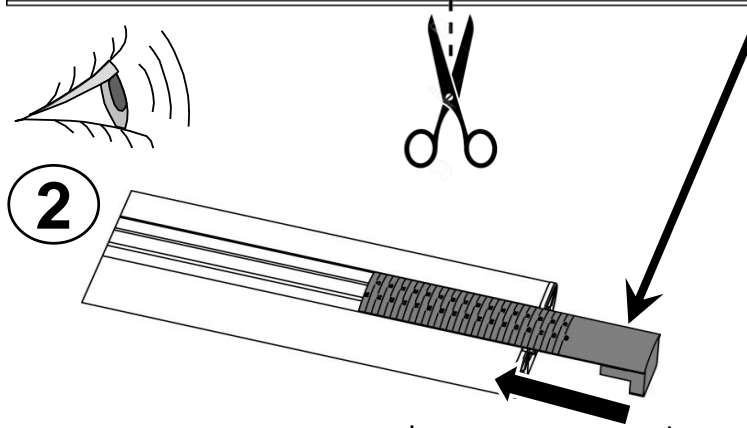
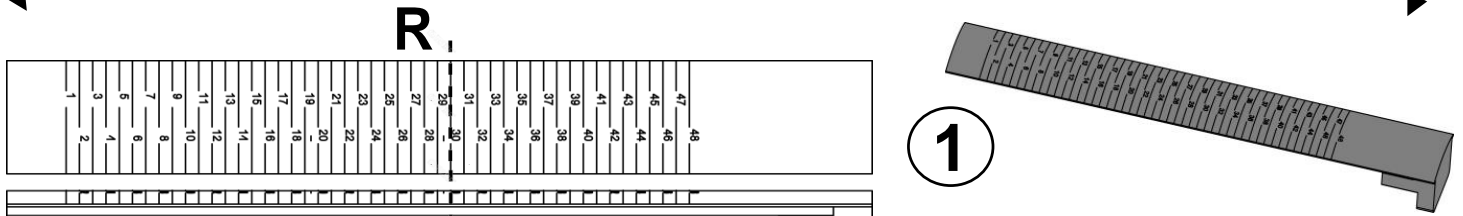
(OPERATION 1 TO 6 NOT FOR IRON BAR)

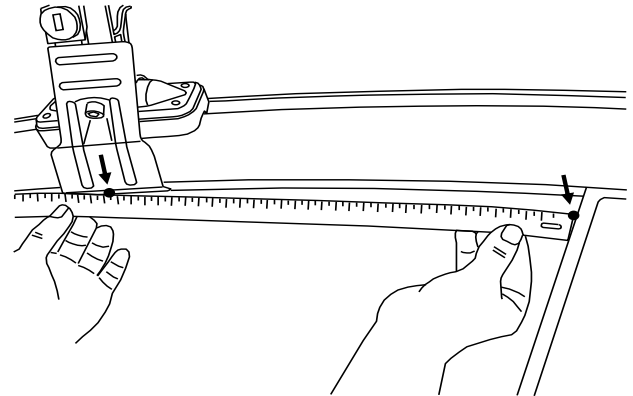
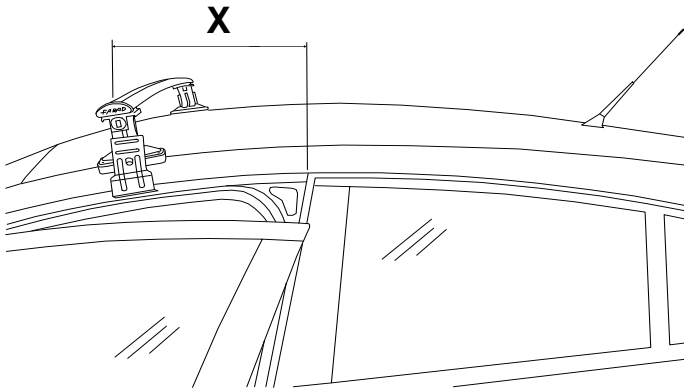
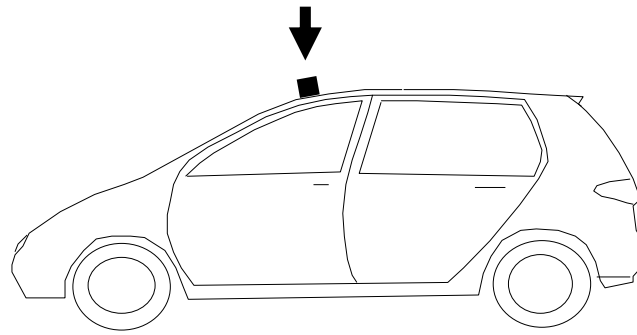

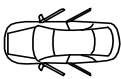
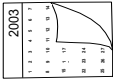

				X
SEAT	ALTEA	5	2004-2015	X= 290
SEAT	TOLEDO	5	2005-2013	X= 290

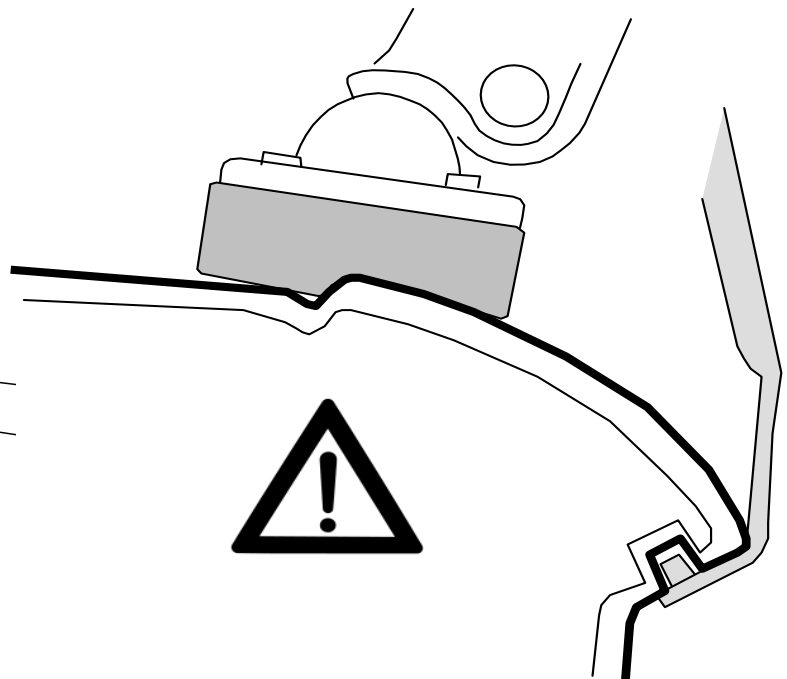
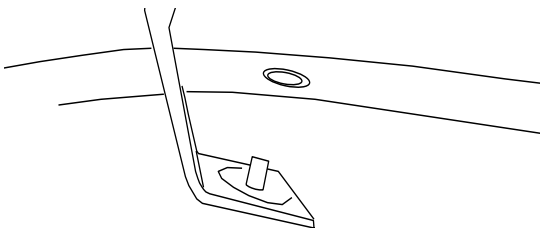
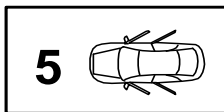

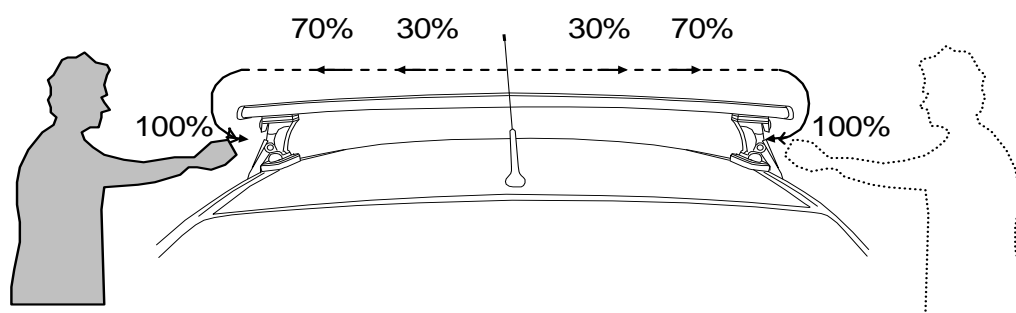
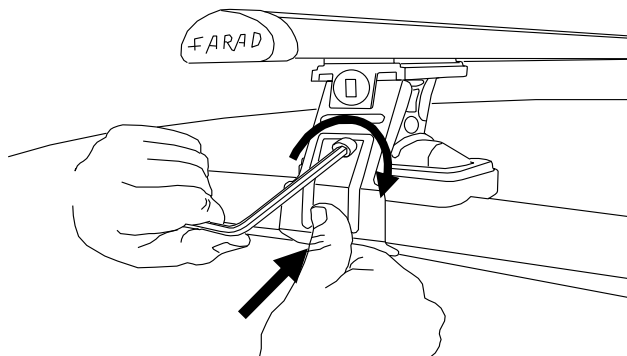
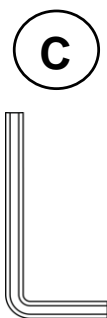

- I Alternare il fissaggio delle viti
- PL Śruby dokręcaj naprzemiennie
- GB Tighten alternately
- NL Afwisselend aan de linker- en de rechterkant aandraaien

- F Serrer alternativement chaque côté
- D Die Schrauben abwechselnd anziehen
- E Apretar alternativamente
- SWE Dra åt växelvis

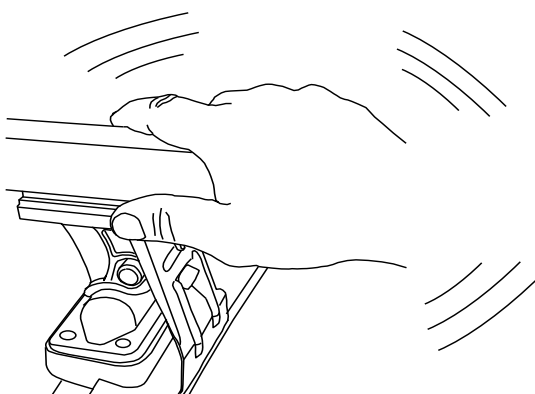

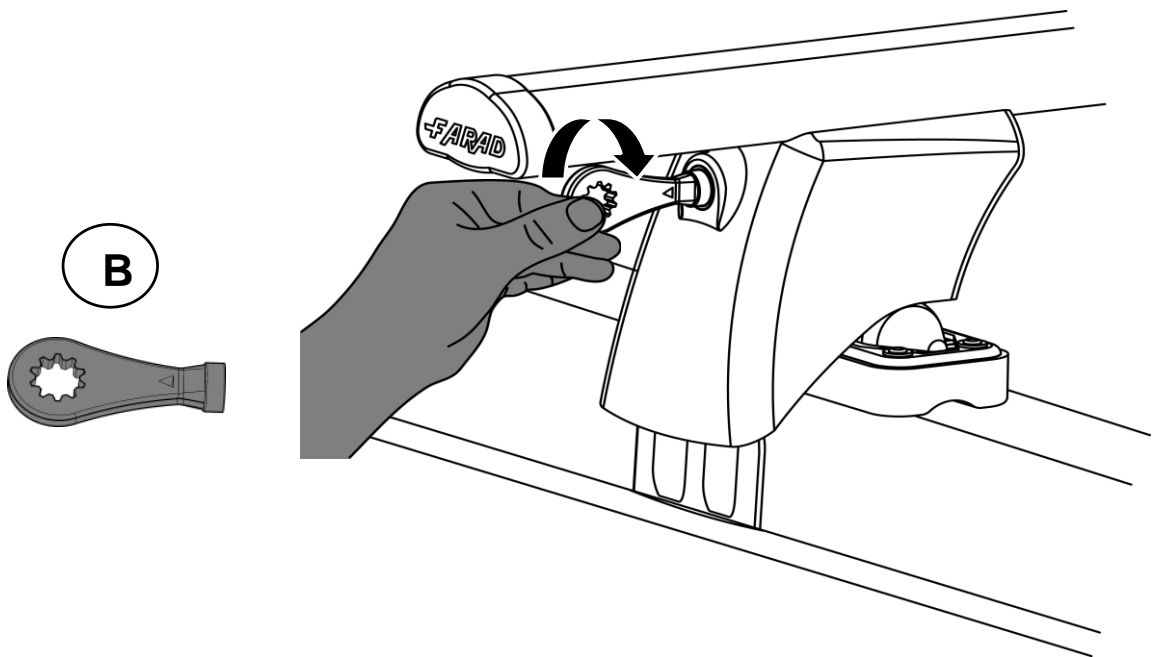
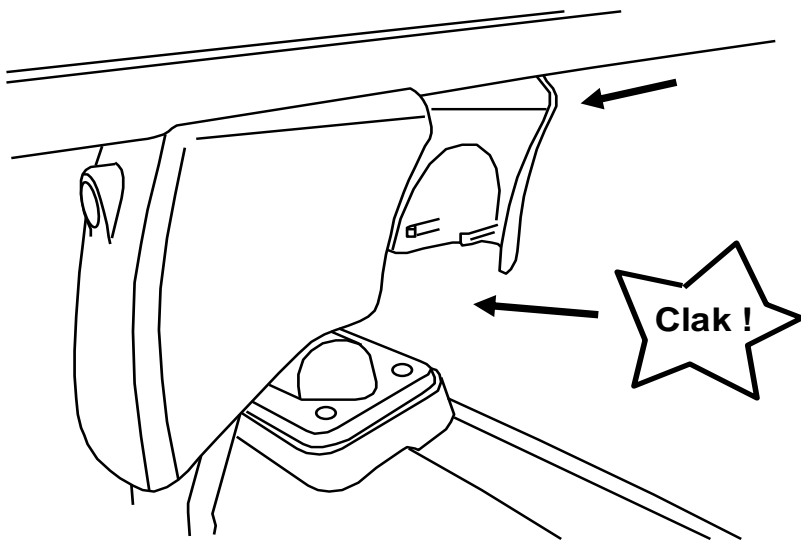
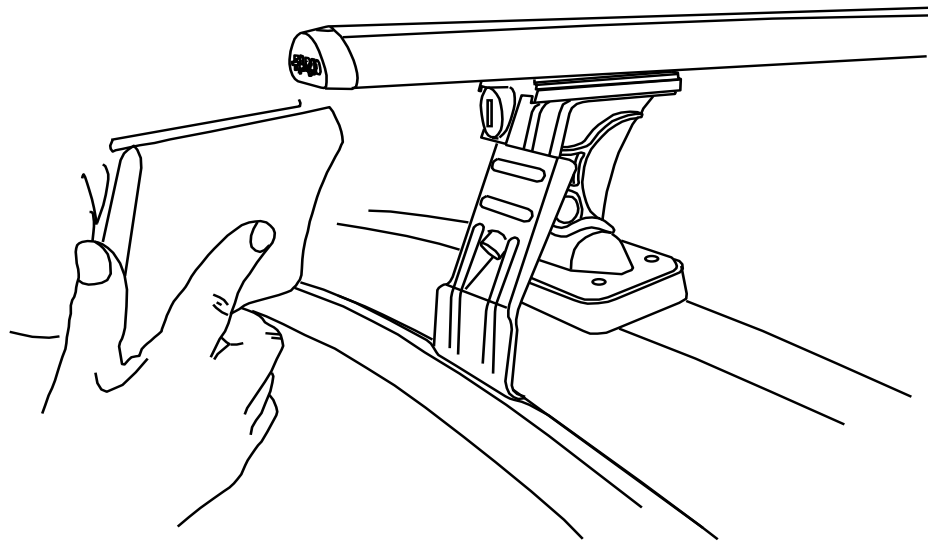

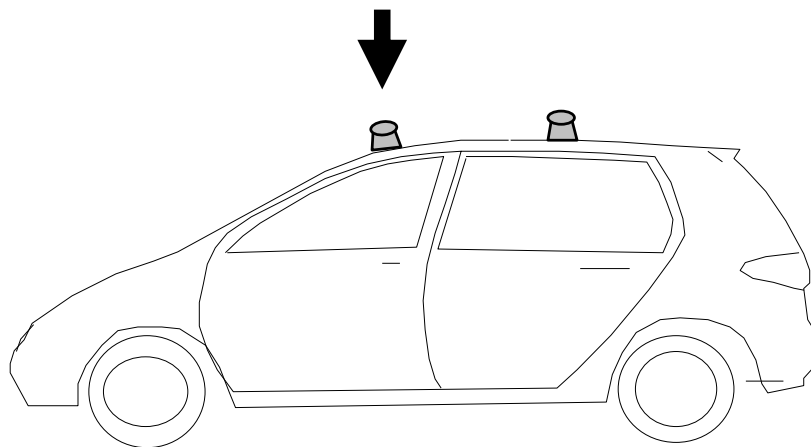

- I** CONTROLLARE PERIODICAMENTE IL FISSAGGIO DELLE VITI
- PL** OKRESOWO SPRAWDZAJ MOCOWANIE ŚRUB
- GB** CHECK THE SCREW FASTENING PERIODICALLY
- D** REGELMÄSSIG ÜBERPRÜFEN DIE BEFESTIGUNG DER SCHRAUBEN
- SWE** REGELBUNDET KONTROLLERA OM FASTSTÄLLANDE AV SKRUVARNA
- F** VERIFIEZ LA FIXATION DES VIS PERIODIQUEMENT

I **Montaggio barra posteriore**

F **Fixation Barre Arriere**

PL **Montaż Bagażnika Bazowego Przedniego**

GB **Fitting Rear Roof Bar**

SWE **Montering Främre Lasthållaren**

E **Fijación Barra Trasera**

NL **Montage Achterste Dakdrager**

D **Montage Heckdachträgers**

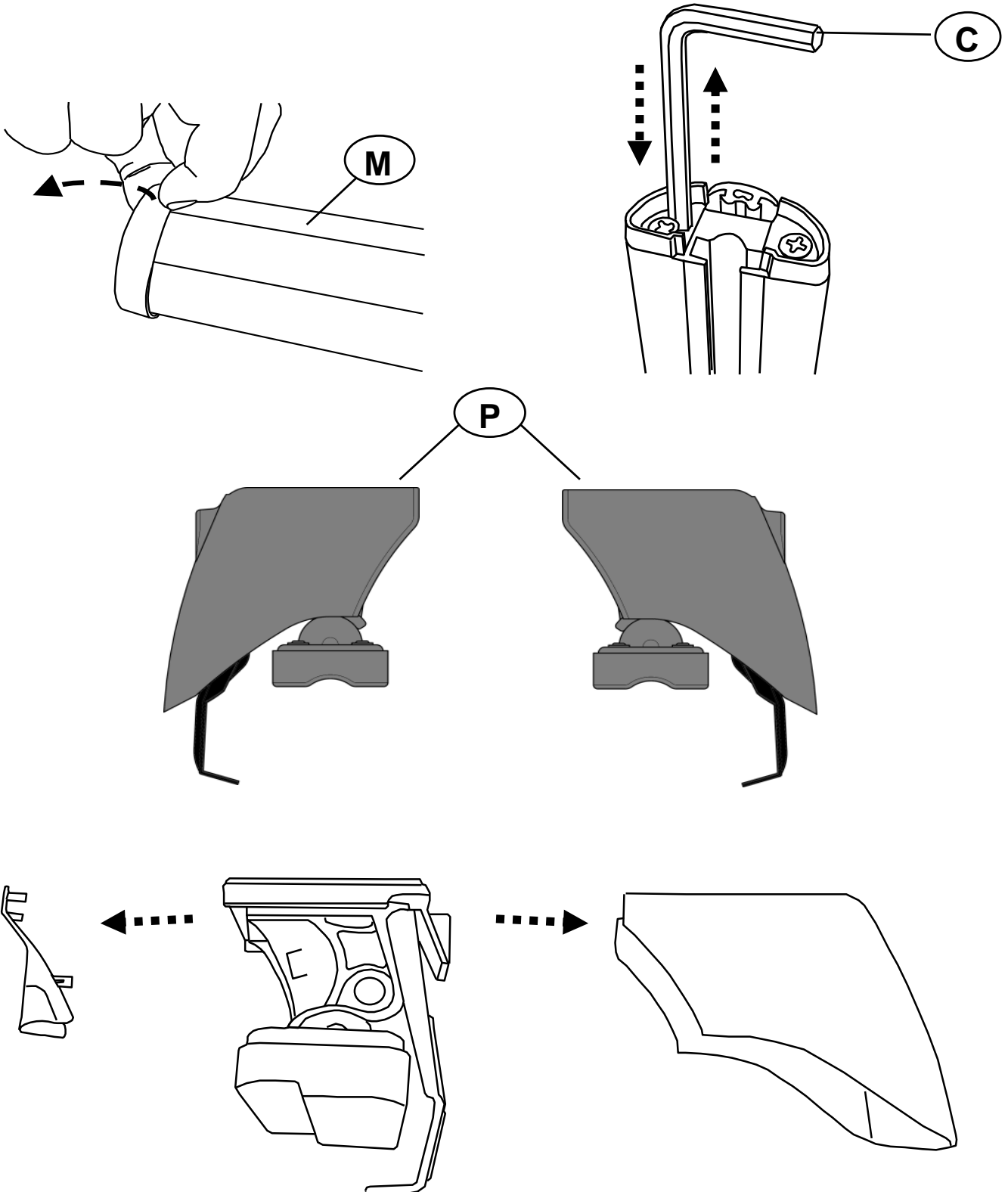



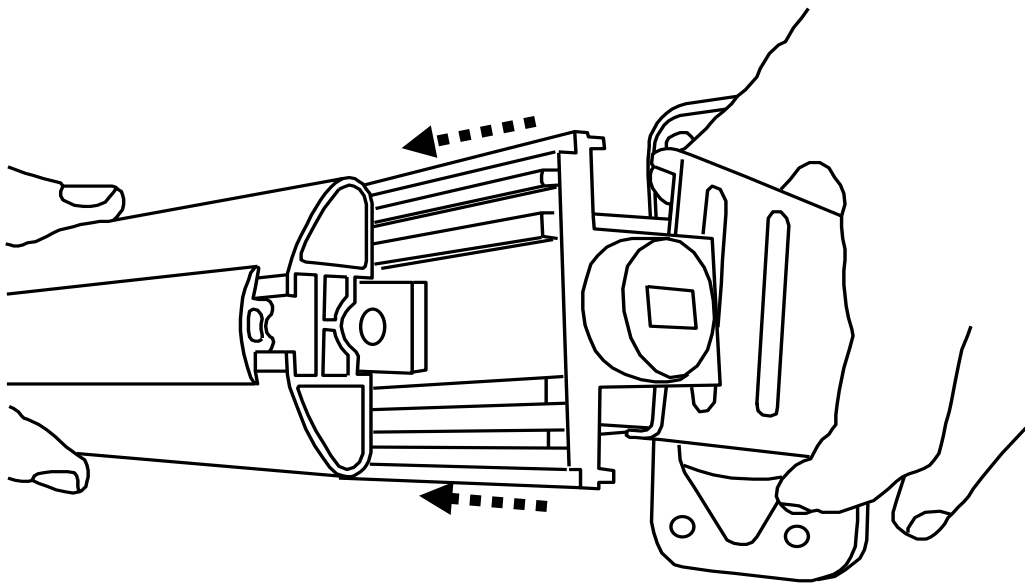
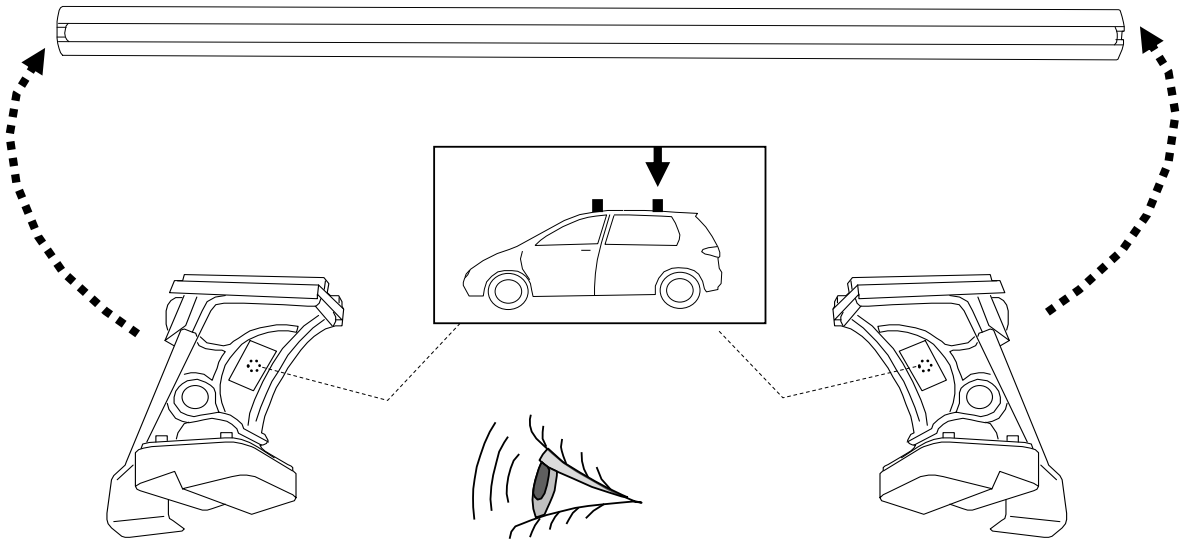

M

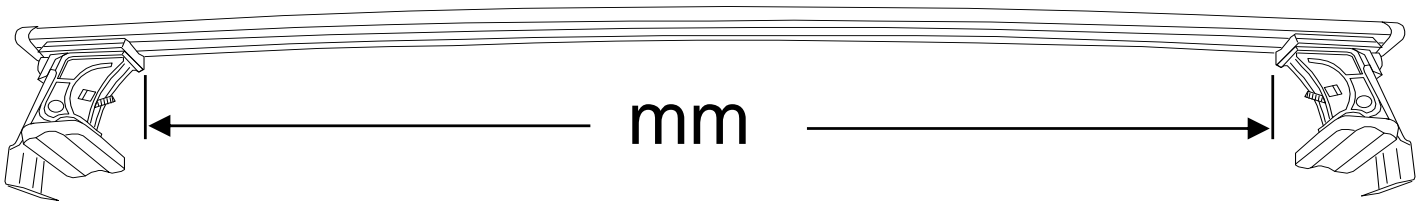





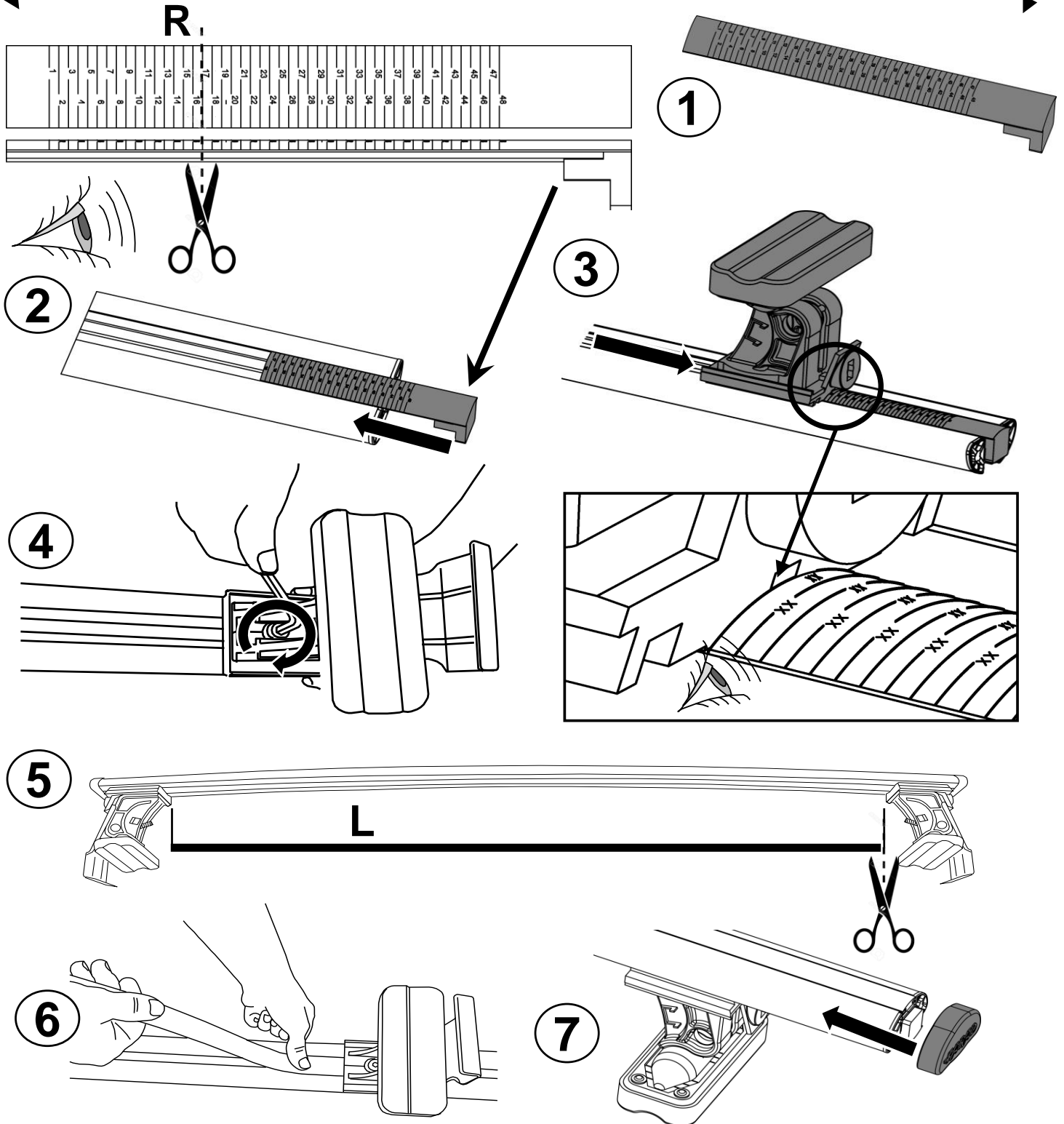

				R	mm
SEAT	ALTEA	5	2004-2015	R= 17	945
SEAT	TOLEDO	5	2005-2013	R= 17	945

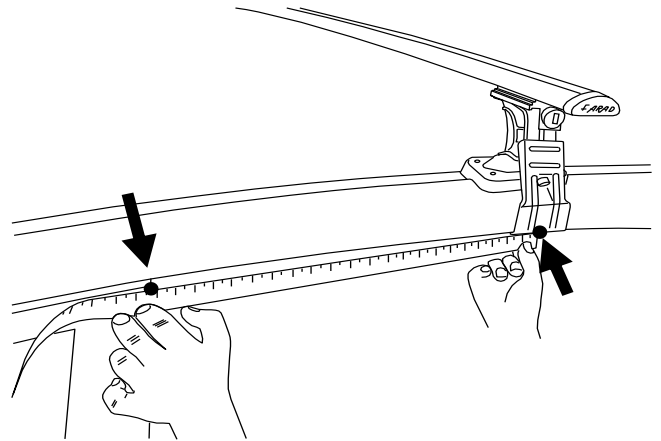
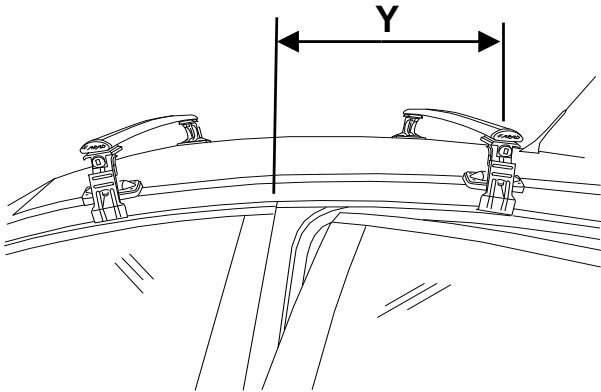
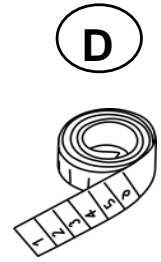
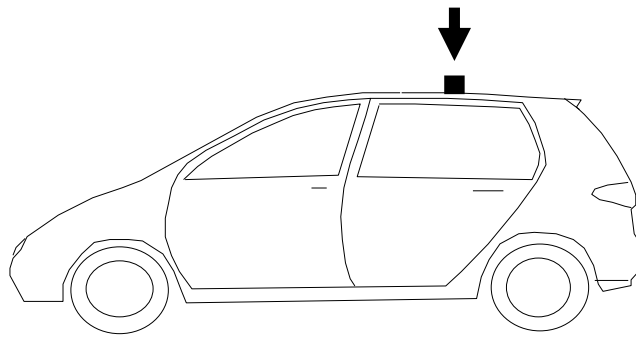
(OPERATION 1 TO 6 NOT FOR IRON BAR)





				Y
SEAT	ALTEA	5	2004-2015	Y= 320
SEAT	TOLEDO	5	2005-2013	Y= 320

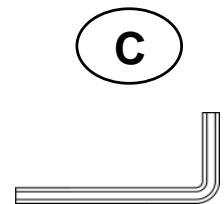
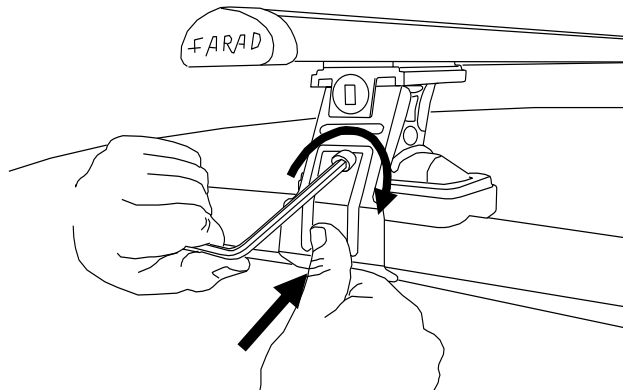
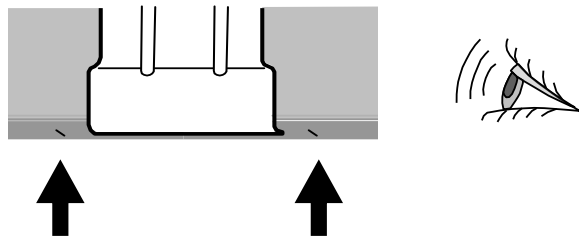
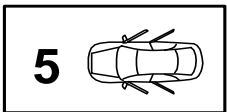

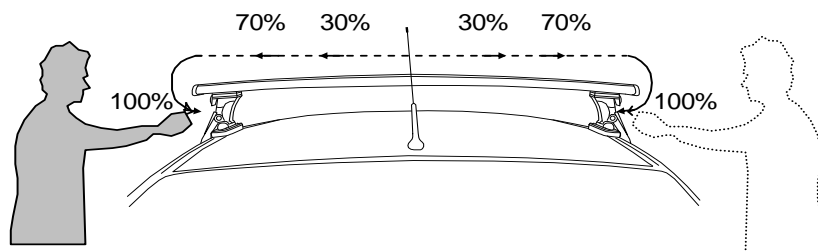

- | | | | |
|----|---------------------------------------------------------|-----|------------------------------------|
| I | Alternare il fissaggio delle viti | F | Serrer alternativement chaque côté |
| PL | Śruby dokręcaj naprzemiennie | D | Die Schrauben abwechselnd anziehen |
| GB | Tighten alternately | E | Apretar alternativamente |
| NL | Afwisselend aan de linker- en de rechterkant aandraaien | SWE | Dra åt växelvis |

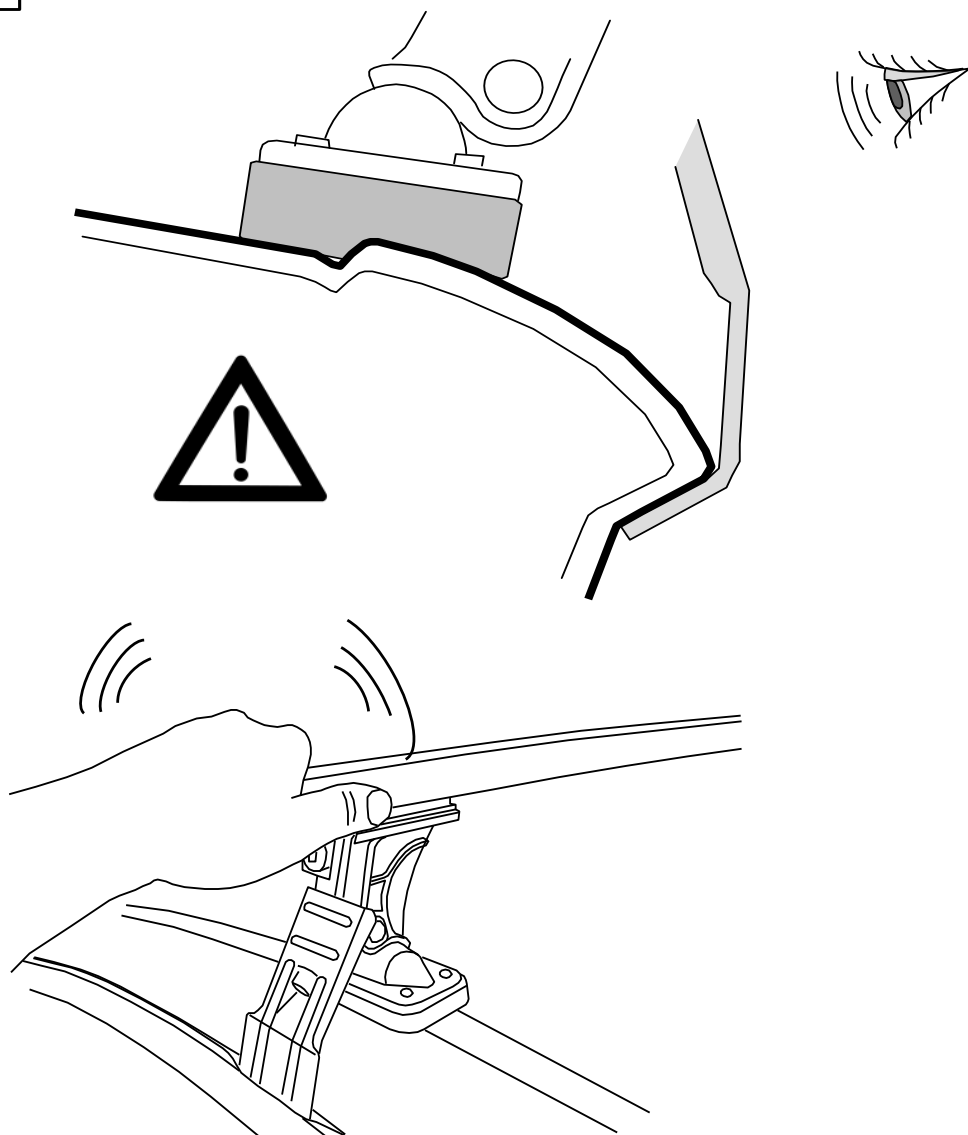
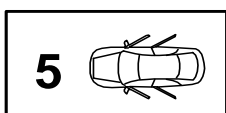

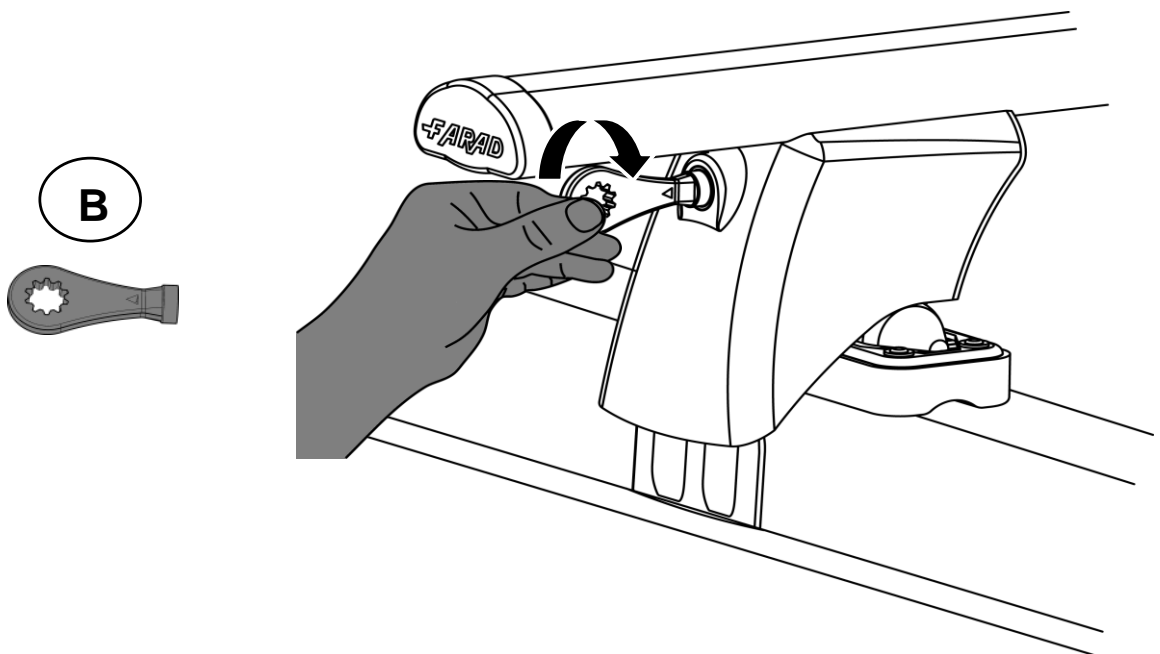
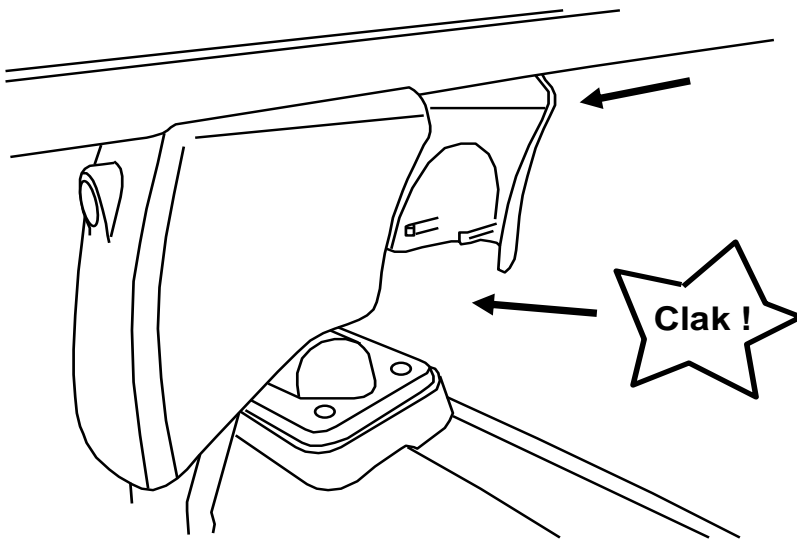
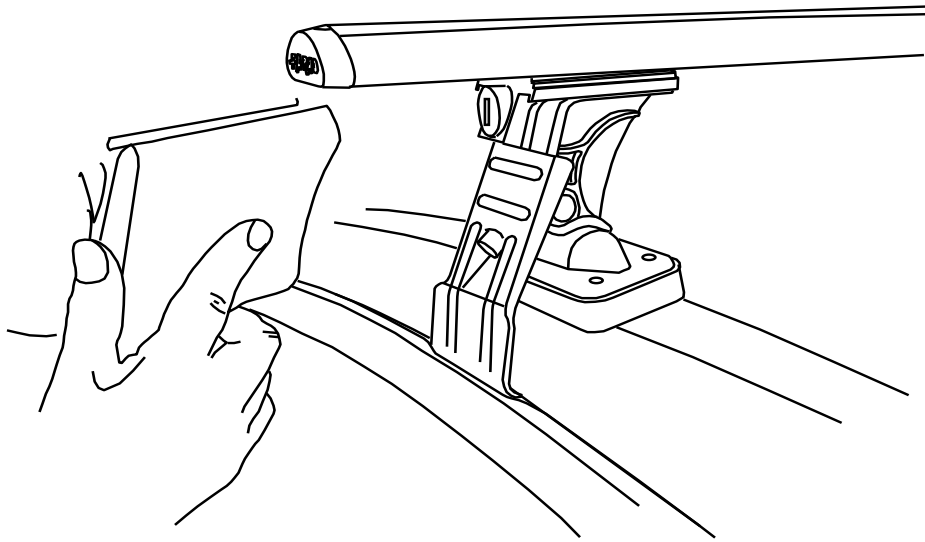

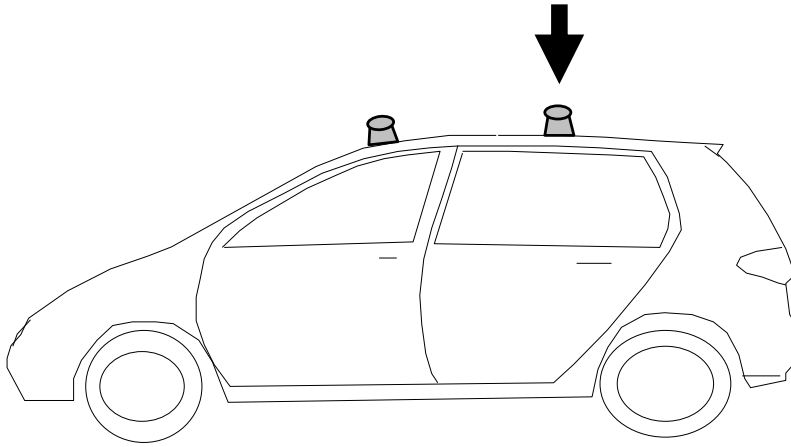

- I** CONTROLLARE PERIODICAMENTE IL FISSAGGIO DELLE VITI
- PL** OKRESOWO SPRAWDZAJ MOCOWANIE ŚRUB
- GB** CHECK THE SCREW FASTENING PERIODICALLY
- D** REGELMÄSSIG ÜBERPRÜFEN DIE BEFESTIGUNG DER SCHRAUBEN
- SWE** REGELBUNDET KONTROLLERA OM FASTSTÄLLANDE AV SKRUVARNA
- F** VERIFIEZ LA FIXATION DES VIS PERIODIQUEMENT

RICAMBI - SPARE PARTS



PIEDE GIREVOLE
90341 / 2

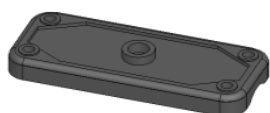

PIEDE FISSO
90341 / 15

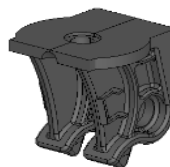

SUPPORTO CENTRALE
90341 / 1

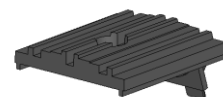

SUPPORTO BARRA
90341 / 5



SOTTO PIEDE SP01
90341 / 3



SOTTO PIEDE SP03
90341 / 16



SOTTO PIEDE SP04
90341 / 13



SOTTO PIEDE SP07
90341 / 11



SOTTO PIEDE SP08
90341/14



SOTTO PIEDE SP10
90341 / 12



SOTTO PIEDE SP12
90341 / 1



CHIAVE ESAGONALE 6
9331 / 148

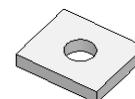

PIASTRINA
90341 / 21



DISTANZIALE
90341 / 20



NOTTOLINO + N° COMB.
90341 / 6



SOTTOTAPPO
90241 / 9



TAPPO BARRA
90241 / 6

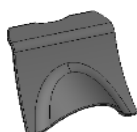

INVOLUCRO POST.
90341 / 9

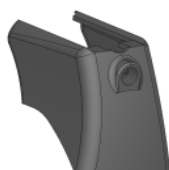

INVOLUCRO ANTERIORE
90341 / 8



CHIAVE + N° COMB
90341 / 7

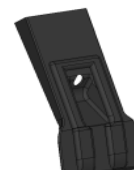

PALETTA
90341 / 4



BARRA ALLUMINIO
90241 / 7

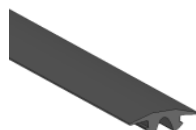

GUARNIZIONE BARRA
90241 / 8



RIGA CARTA
90341 / 19

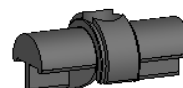

PERNO
90241 / 15

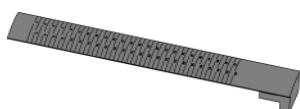

GUARNIZIONE
NUMERICA
91141 / 14

FARAD[®]
made in italy

www.faradworld.com

